

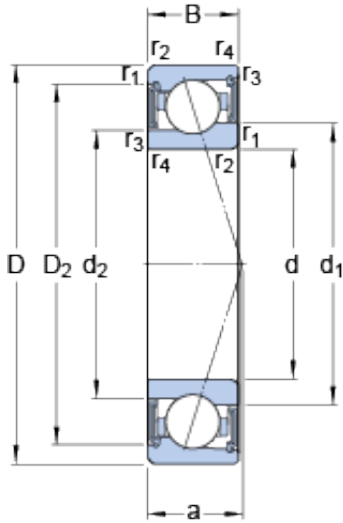

KFY MANUFACTURING MEXICO LIMITED



55 mm x 80 mm x 13 mm SKF S71911 ACE/HCP4A angular contact ball bearings

Bearing No. S71911 ACE/HCP4A

S71911 ACE/HCP4A Bearing 2D drawings and 3D CAD models

Size	80x55x13 mm
Bore Diameter	80 mm
Outer Diameter	55 mm
Width	13 mm
d	55 mm
D	80 mm
B	13 mm
d ₁	62.75 mm
d ₂	60.7 mm
D ₂	74.7 mm
r _{1,2} - min.	1 mm
r _{3,4} - min.	0.3 mm
a	23.5 mm
d _a - min.	59.6 mm
d _a - max.	62.2 mm
d _b - min.	57 mm
d _b - max.	60.1 mm
D _a - max.	75.4 mm
D _b - max.	78 mm
r _a - max.	1 mm
r _b - max.	0.3 mm
Basic dynamic load rating - C	14.6 kN
Basic static load rating - C ₀	10.2 kN
Fatigue load limit - P _u	0.43 kN



KFY MANUFACTURING MEXICO LIMITED

Limiting speed for grease lubrication	25000 r/min
Ball - D_w	7.938 mm
Ball - z	21
Calculation factor - e	0.68
Calculation factor - Y_2	0.87
Calculation factor - Y_0	0.38
Calculation factor - X_2	0.41
Calculation factor - Y_1	0.92
Calculation factor - Y_2	1.41
Calculation factor - Y_0	0.76
Calculation factor - X_2	0.67
Preload class A - G_A	133 N
Preload class B - G_B	400 N
Preload class C - G_C	800 N
Calculation factor - f	1.16
Calculation factor - f_1	0.98
Calculation factor - f_{2A}	1
Calculation factor - f_{2B}	1.04
Calculation factor - f_{2C}	1.08
Calculation factor - f_{HC}	1.01
Preload class A	116 N/micron
Preload class B	178 N/micron
Preload class C	233 N/micron
d_1	62.75 mm
d_2	60.7 mm
D_2	74.7 mm
$r_{1,2}$ min.	1 mm
$r_{3,4}$ min.	0.3 mm
d_a min.	59.6 mm



KFY MANUFACTURING MEXICO LIMITED

d_a max.	62.2 mm
d_b min.	57 mm
d_b max.	60.1 mm
D_a max.	75.4 mm
D_b max.	78 mm
r_a max.	1 mm
r_b max.	0.3 mm
Basic dynamic load rating C	14.6 kN
Basic static load rating C_0	10.2 kN
Fatigue load limit P_u	0.43 kN
Attainable speed for grease lubrication	25000 r/min
Ball diameter D_w	7.938 mm
Number of balls z	21
Preload class A G_A	133 N
Static axial stiffness, preload class A	116 N/ μ m
Preload class B G_B	400 N
Static axial stiffness, preload class B	178 N/ μ m
Preload class C G_C	800 N
Static axial stiffness, preload class C	233 N/ μ m
Calculation factor f	1.16
Calculation factor f_1	0.98
Calculation factor f_{2A}	1
Calculation factor f_{2B}	1.04
Calculation factor f_{2C}	1.08
Calculation factor f_{HC}	1.01
Calculation factor e	0.68
Calculation factor (single, tandem) Y_2	0.87
Calculation factor (single, tandem) Y_0	0.38



KFY MANUFACTURING MEXICO LIMITED

Calculation factor (single, tandem) X_2	0.41
Calculation factor (back-to-back, face-to-face) Y_1	0.92
Calculation factor (back-to-back, face-to-face) Y_2	1.41
Calculation factor (back-to-back, face-to-face) Y_0	0.76
Calculation factor (back-to-back, face-to-face) X_2	0.67
Mass bearing	0.15 kg